

Unbalanced Connections

ABSTRACT

In most broadcast environments, the application of balanced connections does not raise any discussions on how to connect a cable's signal & shield (ground) wires. It is well known that the shield should be grounded at one side only (preferably at a common point) to avoid ground loops that can induce hum or other disturbances.

However, where RF (radio frequency) signals are involved, as e.g. in the digital audio domain, or where an unbalanced connection has to be made, there are many discussions about the best connection, i.e. the "pin 1 topic".

This article tries to clarify this issue from the practical standpoint and provides suggestions on how to connect cables and devices to the A2.

AUDIO SIGNAL GENERATORS

Normally, an audio signal generator has a balanced output stage. Such a generator is called a *floating generator* since it can float at any level to which it is pulled.

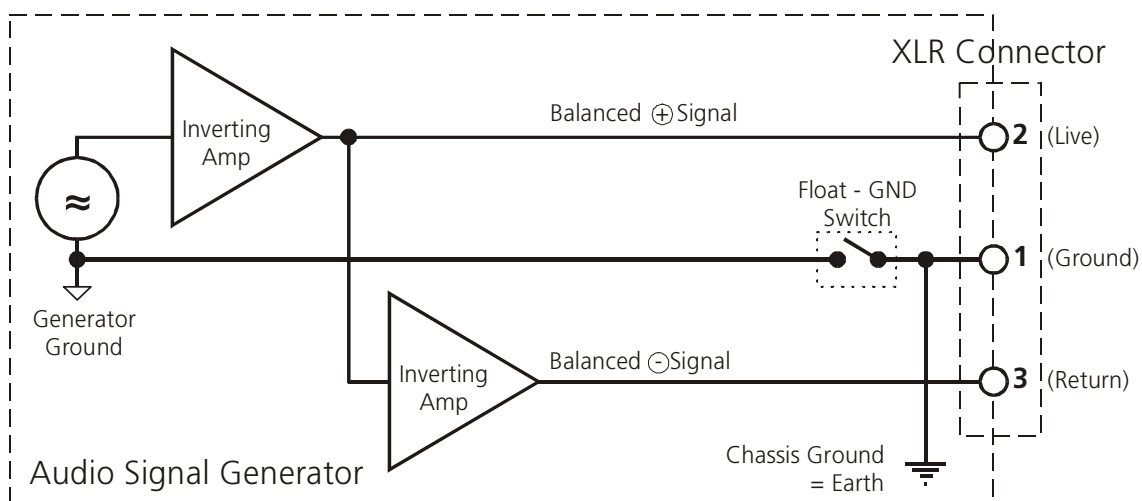

Fig. 1 Floating Generator

The balanced generator produces not just one signal against reference, but also adds a second, inverted signal against the internal reference ground.

Such a balanced connection has the advantage that if noise or hum is introduced during transmission, it is induced into both the + and - transmission lines. On the receiver side, the two signals are subtracted so that any common disturbance is eliminated and the signal level is doubled.

XLR Connectors

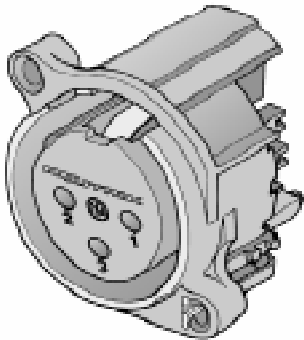

Fig 1 XLR

'XLR' is a mnemonic that stands for:

X	Screen (shield, ground)	⊥	Pin 1
L	Live	+	Pin 2
R	Return	-	Pin 3

Table 1 Definition of XLR

With a balanced output and a balanced load, the reference ground of the generator is always in balance between these two signals at 0 V.

Only if the load is not perfectly balanced, the reference ground of the output will shift to another level than 0 V.

A1 & A2 SIGNAL GENERATOR

The A1 & A2 have an electrically isolated, balanced floating generator. Electrically isolated means that the generator's ground pin can safely withstand any AC or DC potential differences of ≤ 60 Vp to chassis ground.

However, there are some slight design differences in the output stages of these units that need to be considered in practice. They are explained in more detail below.

The Output Stage of the A1

The A1 was designed to have the output pin 1 always fixed to chassis ground (earth). Therefore, pin 1 of the generator connector is permanently wired to chassis ground as shown in **Fig. 2**.

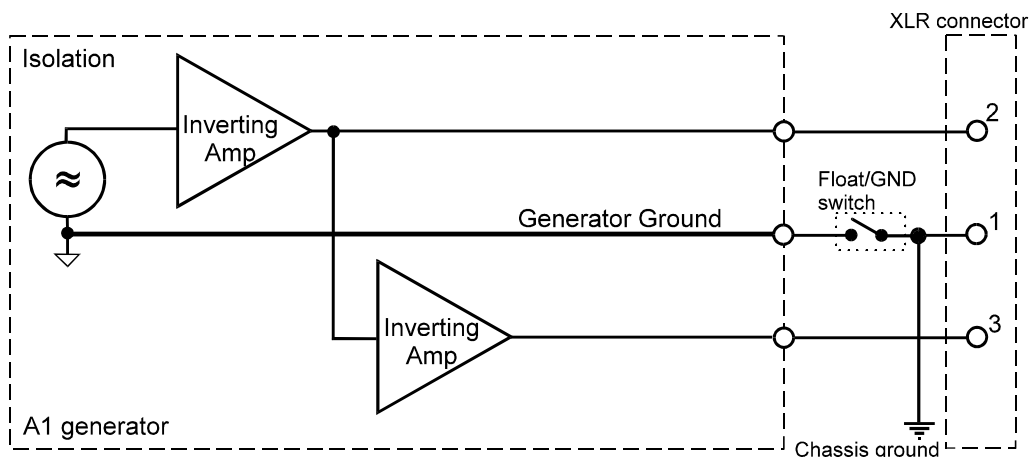

Fig. 2 The A1 Output Stage

By adjusting the FLOAT - GND switch, the generator ground can be kept floating or connected to chassis ground (earth), i.e. pin 1 of the XLR.

The Output Stage of the A2

Like the A1, the A2 comprises of an electrically isolated, balanced floating generator with a switch that allows to connect the generator ground to pin 1 of the XLR, i.e. chassis ground.

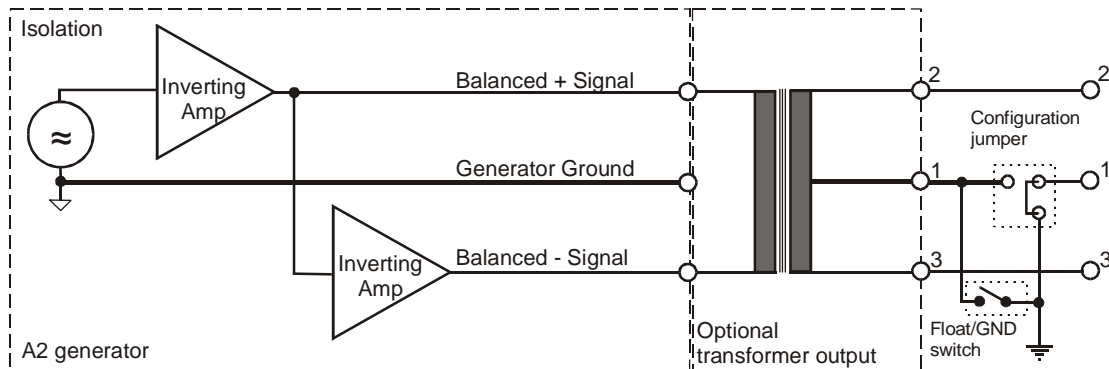

Fig. 3 A2 Floating Generator

However, there are two major differences to the A1 output stage as shown in **Fig. 3**:

1. In addition to the FLOAT – GND switch, there is a 'Configuration Jumper' that allows to disconnect pin 1 of the XLR from chassis ground and to connect it to the generator ground instead.
2. An optional transformer output may be inserted to establish a complete electrical isolation of the generator outputs from the XLR connector.

The settings and additional effects of this configuration jumper are explained in more detail in chapter **Balanced Connections with A2 (p. 5)**.

THE FLOAT – GND SWITCH

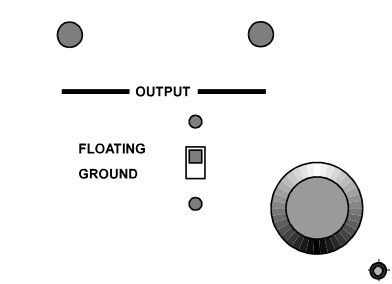

Fig. 4 Float - Ground Switch

By using the FLOATING – GROUND switch at the rear panel of the A2, the user has the choice to

- let the center tap (pin 1) of the generator float *or*
- to tie pin 1 to a fixed level as e.g. chassis ground of the cabinet.

In the position FLOATING, the center tap of the generator may float to any level and has no connection to the chassis ground. In the position GROUND, the center tap is connected to the chassis ground of the A2 respectively (see also **Fig. 2** and **Fig. 3**).

Balanced Connections

If the A1 or A2 is used as a *balanced* signal generator – the standard application – it is wired to the balanced input pins 2 & 3 of the connected device.

In this setup, the FLOAT – GND switch must be adjusted according to following rules:

1. If the audio-signal (pin 2 & 3) might be superposed by a common DC-component, the FLOAT – GND switch has to be put to position „FLOAT“ to allow the generator.
2. If no common signal or DC offset is expected, it doesn't matter whether the switch is in position „FLOAT“ or „GND“.

NOTE It is strongly recommended to keep the FLOAT – GND switch in position FLOAT.

Unbalanced Connections

If an *unbalanced* connection must be established between the A1 / A2 output stage and the connected device, e.g. due to the lack of a XLR input connector, there are two alternatives:

a) Pin 2 – Pin 1

One signal of the balanced output stage only (pin 2 or pin 3) together with pin 1 (ground) is used to wire the unbalanced connection. In this case a signal level loss of -6 dB (i.e. half of the balanced output level) vs. the selected output level occurs.

In this setup it is necessary to have the FLOAT – GND switch in position GND since the generator ground must be connected to the signal ground (e.g. shield) as shown in **Fig. 5**.

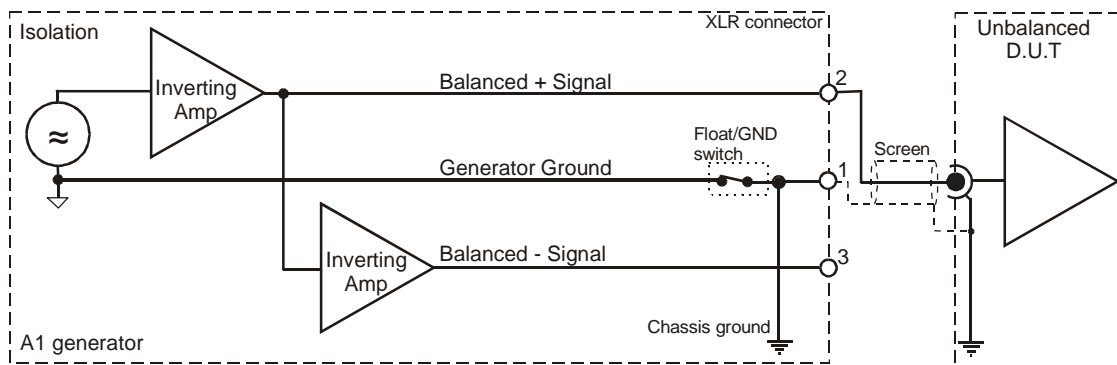

Fig. 5 Unbalanced Connection with 6dB Loss

NOTE If the generator pins 1 & 2 are wired to the connected device only, a loss of -6 dB (i.e. -50%) of the actual output level vs. the selected output level will occur.

b) Pin 2 – Pin 3

Alternatively, by wiring pin 2 of the A1 / A2 generator to the hot input of the unbalanced device and pin 3 of the A1 / A2 generator to the device ground (shield), the loss of the -6 dB is avoided.

In this setup, the FLOAT – GND switch must be put to position FLOAT, i.e. the generator ground has to be left open as shown in **Fig. 6**.

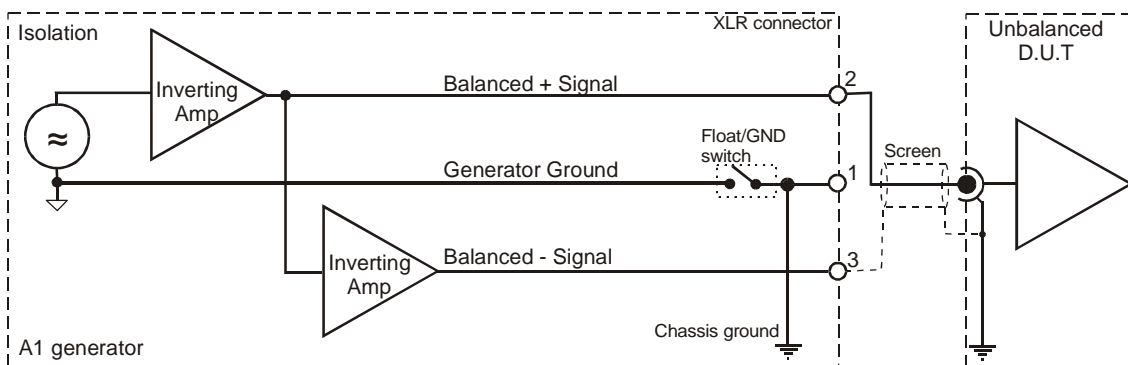

Fig. 6 Unbalanced Connection without Loss

Furthermore, in the FLOAT mode it is possible to connect the A1 / A2 output pins 1 & 3 together so that pin1 (but not the generator ground) is at the same level as pin 3. This configuration is also standard e.g. in a XLR – BNC adapter.

Please take care not to put the FLOAT-GND switch to position GND if pin 1 & 3 are shorted (in this setup, a -6 dB loss will occur again). Even though this would not destroy any devices in the A1 / A2, it is not recommended to short circuit a power amplifier for hours. An effect that could occur in such a situation is that the power amplifier shuts down due to overheating with an error message. Nevertheless, it will resume to work after cooling down.

THE 'PIN 1 PROBLEM'

Many broadcast setups are configured in a way that their balanced input devices have pin 1 permanently wired to chassis ground. If an A1 or A2 is used in such a setup, the connecting XLR cables would be tied to ground on both ends which would result in unwanted ground loops. Therefore, either pin 1 shall not be connected to ground on the A1 / A2 output side or the screen of the cable must be disconnected.

A possible solution for this problem would be to have pin 1 connected to the generator ground (or the center tap of an output transformer) in the A1 / A2. Thus, pin 1 would not be connected to ground as long as the FLOAT - GND switch is in position „FLOAT“, regardless whether the connected device is balanced or not.

Contrary to the needs of low frequency audio applications, the best RF protection in a balanced setup is obtained if the screen is connected to ground at both ends of the cable.

Actually, both approaches have their PROs and CONS and the preferences in the various broadcasting organisation around the world are equally distributed. The best solution would be a „silent shield“ cable with two isolated coaxial screens, whereby the inner screen would be grounded at one end for best LF protection, and the outer screen, responsible for RF immunity, grounded at both ends.

Balanced Connections with A2

The fact that balanced connections with pin 1 permanently tied to ground may cause problems resulted in a new output stage wiring in all A2 units with serial number ≥ 400 .

Therein, an additional jumper was introduced that allows to connect pin 1 either to chassis ground or to the center tap of the transformer output. On the other hand, the FLOAT - GND switch was not changed; it is wired in the same way as all older units.

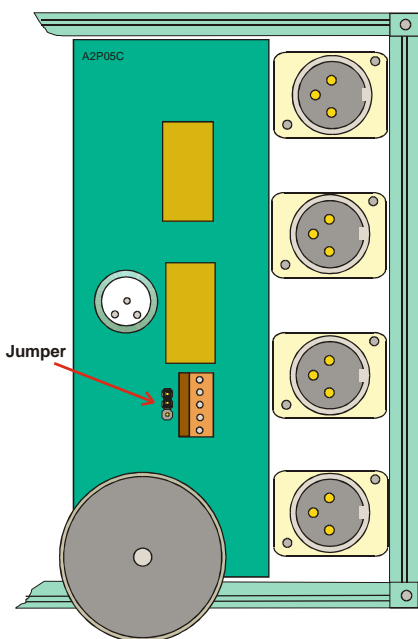

Fig. 7 A2 Jumper

The jumper is located inside the A2. To get access to it, remove the four corner screws of the front panel and dismount it. Aside of the four XLR input/output connectors is a small PCB with the jumper on it.

In the upper position (see **Fig. 8**), the XLR output pin 1 is connected to generator ground as it is recommended for balanced setups with a screen connection on one side only. Please notice that this configuration is the same as in the A2 units with S/N < 400.

Obviously, the FLOAT - GND switch leaves the generator ground floating or ties it to chassis ground in position GND.

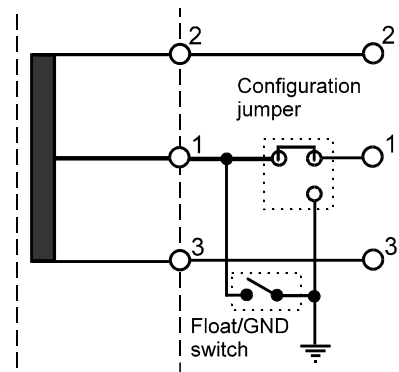

Fig. 8 Jumper Upper Pos.

In the lower position (**Fig. 9**), pin 1 is permanently connected to chassis ground, which is the factory default setting.

In this position, the generator ground is floating (position „FLOAT“) or connected to chassis ground (and pin 1) with the switch in position „GND“.

Unbalanced connections are best made with the jumper in the *lower* position, wherein pin 1 is always at chassis ground level. This configuration is identical to the wiring in the A1. Consequently, everything mentioned above also applies for A1 unbalanced connections. Please refer to **Fig. 5** and **Fig. 6** to find the correct wiring.

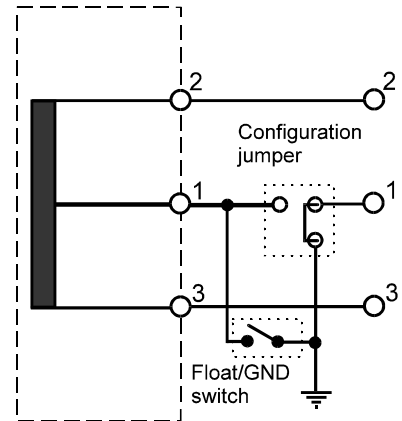

Fig. 9 Jumper Lower Pos.